

AUDIOPHILE

Front-End Audio Processing and Voice Detection System

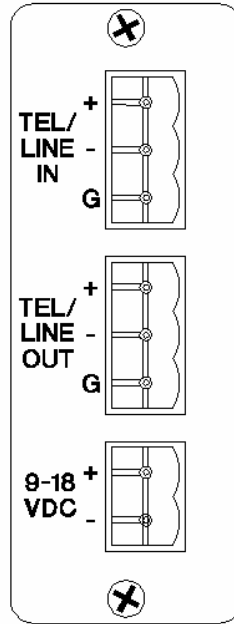

HARDWARE USER'S MANUAL

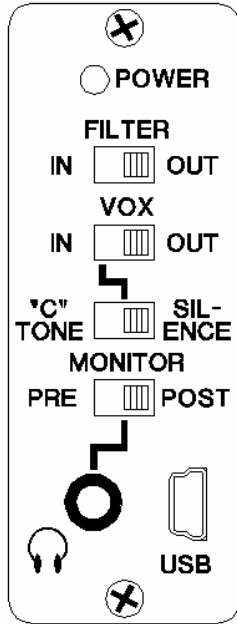

Digital Audio Corporation
a DRI company

4018 Patriot Drive, Suite 300 Durham, NC 27703

AUDIOPHILE

Front-End Audio Processing and Voice Detection System

Hardware User's Manual

March 15, 2006
Document Number 060315ADT



Digital Audio Corporation
a DRI company

4018 Patriot Drive, Suite 300 Durham, NC 27703

Phone: 919 572 6767

Fax: 919 572 6786

sales@dacaudio.com

www.dacaudio.com

Copyright © 2006 by Digital Audio Corporation
All rights reserved.

TABLE OF CONTENTS

1.0 OVERVIEW	4
1.1 Introduction	4
1.2 Original Factory Configuration	4
1.3 Custom Filter Configuration	5
2.0 OPERATION	6
2.1 Controls and Connectors	6
2.1.1 Front Panel	6
2.1.2 Rear Panel	7
2.2 Signal Processing Flow	10
4.0 CALIBRATION AND SERVICE	11
5.0 AUDIOPHILE SPECIFICATIONS	12
5.1 Power	12
5.2 Analog	12
5.3 Digital	12
5.4 Physical	13

1.0 OVERVIEW

1.1 Introduction

AUDIOPHILE is a specially-designed compact processor unit that provides both real-time noise reduction processing and voice detection capabilities for applied live or recorded signals. Designed for either rack-mount or stand alone usage, this powerful signal processor is fully self-contained and features:

- Compact size at 1.1"W x 2.8"H x 6.0"D
 - Extruded aluminum enclosure with black anodized panels
 - Optional 2U x 19" rackmount panel, capable of supporting as many as 14 AUDIOPHILE units
- Transformer- and AC-coupled 600-ohm balanced audio inputs and outputs, utilizing two-piece "Phoenix" terminal connectors, suitable for direct connection to most audio and telco equipment
- Low-noise analog circuitry and 24-bit professional-grade audio codec for high-performance audio throughput and digital filtering
- Latest-technology Texas Instruments floating-point DSP
- Multi-stage LMS adaptive, adaptive spectral inverse (ASIF), adaptive spectral subtraction, and automatic gain control (AGC) processing
- Smart "VOX" algorithm, operating directly on the filtered audio signal
 - When VOX active, either standard "C-Tone" output or silence whenever speech not present
- Standard 7.5kHz audio bandwidth (18000 Hz sample rate)
- 9-18VDC power input
- Front-panel switches for controlling filtering, VOX, and C-Tone or silence selection
- Interactive Windows® software, operating through the front-panel USB connection and allowing complete configuration of all processing and voice detection parameters
- Internal flash memory storage of all processing and voice detection parameters

1.2 Original Factory Configuration

The original factory configuration stored in the AUDIOPHILE unit is optimized for noise removal and clarification of typical live and recorded voice signals. It is also optimized for detecting embedded voice in most typical audio signals. The factory configuration consists of a combination of LMS adaptive filtering (for machinery or other predictable broadband noise reduction), spectral subtraction filtering (for static or other random broadband noise reduction), automatic spectral inverse filtering (for spectral equalization and voice

intelligibility improvement), automatic gain control (for near/far party volume compensation), and smart “VOX” voice activity detection.

1.3 Custom Filter Configuration

- For non-typical situations, the flash memory configuration can easily be modified through the front-panel USB port using the Windows software utility. The software also includes the factory configuration as one of its standard options, so that the original state of the AUDIOPHILE can be restored at anytime. Please refer to the *AUDIOPHILE Configuration Software User’s Manual* for further details on using the Windows software utility.

2.0 OPERATION

AUDIOPHILE is easy to setup and operate. The following section discusses the connections and controls for the unit.

2.1 Controls and Connectors

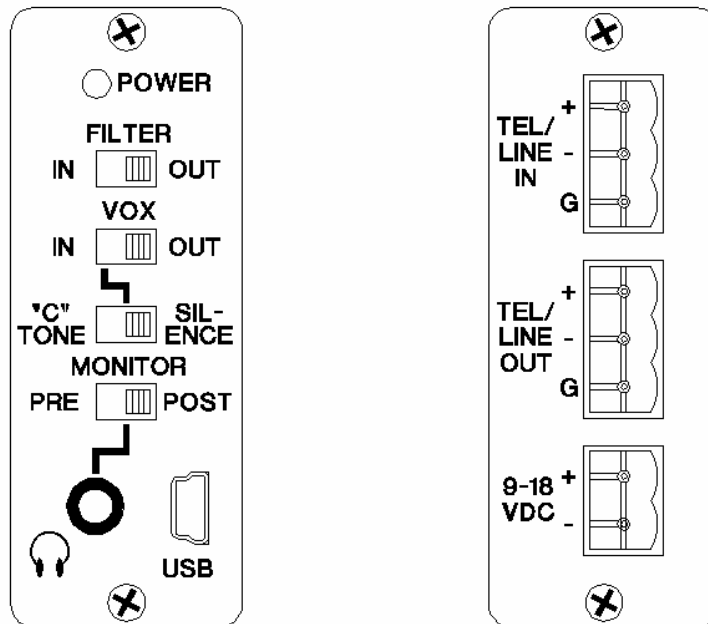

Figure 1: AUDIOPHILE Front and Rear Panels

2.1.1 Front Panel

Refer to Figure 1 for an illustration of the front and rear panels.

- The **POWER** LED indicates that DC power is applied to the rear panel connector and that the unit is operating.

NOTE: there is no power on/off switch; the unit is always “on” whenever power is applied

- The two-position **FILTER IN/OUT** switch selects the state of the noise reduction processor filter stages. To have the AUDIOPHILE process (filter) the input signal, flip the switch left to **IN**. To have the AUDIOPHILE bypass the two filter stages (no filter), flip the switch right to the **OUT** position.

- The two-position **VOX IN/OUT** switch selects the state of the speech-detecting “smart VOX” algorithm. To make the VOX active, flip the switch left to **IN**. To make the VOX inactive, flip the switch right to the **OUT** position. Whenever the VOX is **IN**, the second two-position slide switch selects either “**C**” **TONE** or **SILENCE** to replace the non-speech portions of the output audio routed to the **TEL/LINE OUT** connector, so as to indicate to the subsequent recording equipment which portions should not be recorded.

NOTE: changing the setting on either the FILTER or the VOX switches will affect the audio output from the TEL/LINE OUT connector. This may affect any subsequently connected recording equipment

- The **MONITOR PRE/POST** switch specifies whether the original input audio from the **TEL/LINE IN** connector (“**PRE**” process) or the final output audio to the **TEL/LINE OUT** connector (“**POST**” process) is routed to the stereo headphone jack for listening. In either position, the audio output from the **TEL/LINE OUT** connector will be unaffected.

NOTE: in the PRE position, the audio heard on the headphones will not be affected by the other three switches. Make sure to select POST if you are trying to hear the result of the FILTER and VOX settings

- The **USB** port is used to download new settings for the FILTER and VOX processing. The supplied Windows software and cable are required to perform this function. Please refer to the *AUDIOPHILE Configuration Software User’s Manual* for further details on using the software.

2.1.2 Rear Panel

Refer to Figure 1 for an illustration of the front and rear panels.

- The **TEL/LINE IN** is a 3-pin Phoenix-type connector with removable terminal strip plug that provides balanced, line-level input of a single (monaural) audio signal to the AUDIOPHILE processor. The input circuitry is 600-ohm transformer coupled, and is designed to be compatible with both “wet” and “dry” pair telephone line connections, in addition to normal line-level audio signals from audio recording equipment, amplifiers, etc. Refer to Figure 2 for a conceptual diagram of how the rear panel input connection is coupled to the input circuitry.

NOTE: for proper connection of the input signal, please make sure that the signal pair (whether balanced or single-ended) is connected to the “+” and “-“ pins on the connector, otherwise the signal will not couple properly through the transformer to the internal circuitry. The “G” (ground) pin is normally left unconnected for maximum common-mode noise rejection, but it is available as a backup connection for a “shield” conductor, in the event that the signal source does not have a suitable ground connection available for this purpose

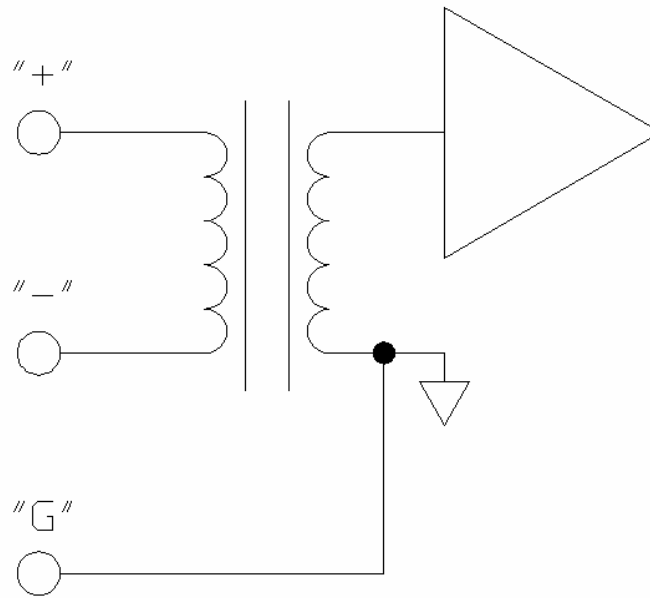

Figure 2: TEL/LINE IN Receiver Conceptual Diagram

- The **TEL/LINE OUT** is a 3-pin Phoenix-type connector with removable terminal strip plug that provides balanced, line-level output of a single (monaural) audio signal from the AUDIOPHILE processor. The output circuitry is 600-ohm transformer coupled, and is designed to be compatible with both “wet” and “dry” pair telephone line connections, in addition to normal line-level audio signal inputs to audio recording equipment, amplifiers, etc. Refer to Figure 3 for a conceptual diagram of how the audio output circuitry is coupled to the rear panel output connection.

NOTE: for proper connection of the output signal, please make sure that the signal pair is connected to the “+” and “-” pins on the connector, otherwise the signal will not couple properly through the transformer from the internal circuitry. In the case of a balanced pair connection, the “G” (ground) pin can optionally be connected to the “shield” conductor that may be available in the cable. In the case of single-ended and/or coaxial cable connections, the “G” and “-” pins should both be connected to the shield/ground conductor, with the “+” pin connected to the signal conductor

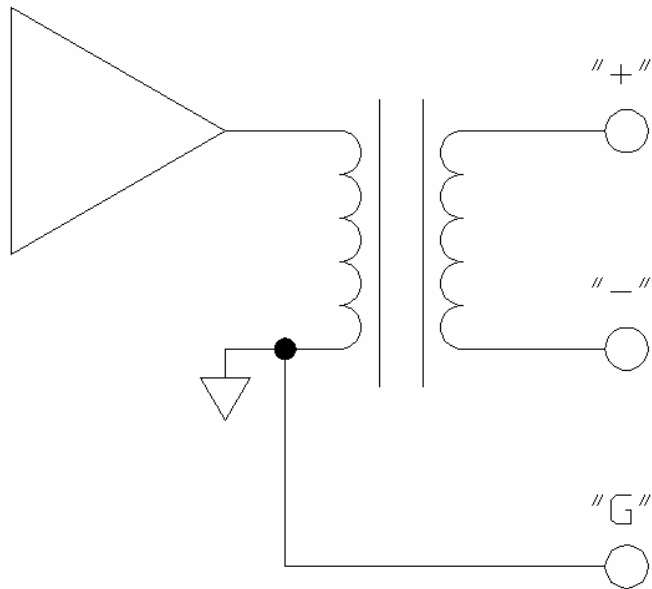

Figure 3: TEL/LINE OUT Driver Conceptual Diagram

- The **9-18 VDC** power input connector is a 2-pin Phoenix-type connector with removable terminal strip plug. The supplied universal AC adaptor connects to this jack, but alternatively power can be supplied from any DC source in the range of 9-18VDC that has sufficient current available for powering the AUDIOPHILE electronics (1 Ampere minimum supply current recommended).

NOTE: there is no power on/off switch; the unit is always “on” whenever power is applied

2.2 Signal Processing Flow

It is important to understand how audio flows through the AUDIOPHILE system. Please refer to Figure 4 for the functional block diagram.

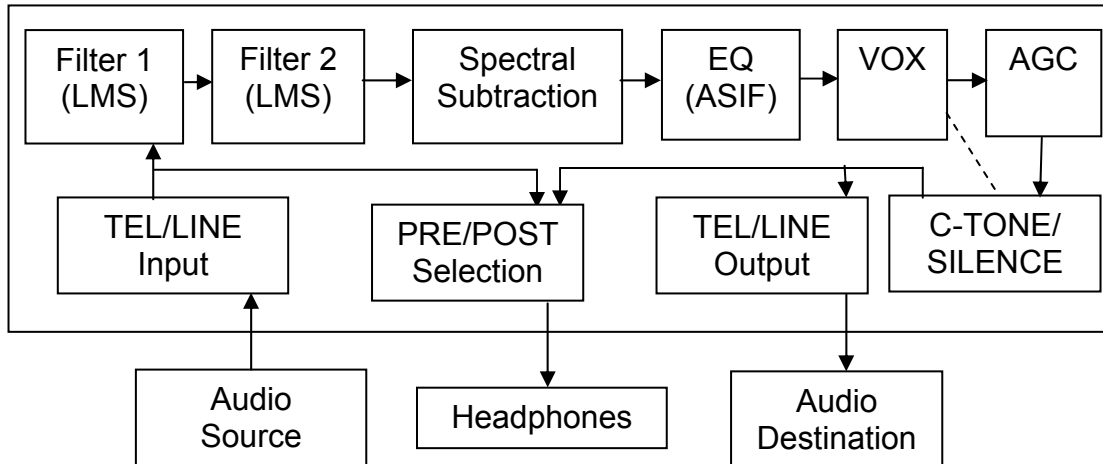

Figure 4: AUDIOPHILE Functional Block Diagram

Not shown in the diagram are the **FILTER IN/OUT** and **VOX IN/OUT** switches; the **FILTER** switch allows switching all the processing except for the VOX in and out of the signal flow path. The **VOX** is switched in and out separately.

NOTE: there is no input level adjustment required; the AUDIOPHILE is set to a fixed input level that offers maximum input dynamic range

4.0 CALIBRATION AND SERVICE

The AUDIOPHILE is designed to make periodic calibration unnecessary.

5.0 AUDIOPHILE SPECIFICATIONS

5.1 Power

9-18VDC input:

- 2-pin Phoenix jack, 0.2" pin spacing
- Accepts regulated or unregulated power, within specified range
- Universal AC power adaptor with compatible plug supplied

5.2 Analog

Analog Input:

- 3-pin Phoenix jack, 0.2" pin spacing (compatible screw-terminal plug included)
 - $2V_{rms}$ maximum input voltage
 - Fixed gain amplifier, nominal 0dB pass-through from input to output
 - $Z_{in} = 600\Omega$, AC-coupled
 - Transformer-coupled balanced signaling, suitable for connection to either audio or telco equipment

Analog Output:

- 3-pin Phoenix jack, 0.2" pin spacing (compatible screw-terminal plug included)
 - $2V_{rms}$ maximum output voltage
 - $Z_{out} = 600\Omega$, AC-coupled
 - Transformer-coupled balanced signaling, suitable for connection to either audio or telco equipment

Headphone Jack:

- 3.5mm stereo mini-jack (headphones not included)
- $1V_{rms}$ maximum output voltage
- Automatic level control (only applied to headphone jack, not analog output)
- Selector switch for PRE or POST audio filter listening

Analog Conversion:

- 24-bit, 256x-oversampling, sigma-delta codec
- >90dB SINAD, >100dB dynamic range

5.3 Digital

Control Interface:

- USB 2.0 full-speed interface
- 5-pin "mini-B" connector
- Allows custom configuration via the supplied Windows software and interconnect cable

LED Indicators:

- POWER on LED only

Bandwidth:

- 35Hz to 7.5kHz, 18kHz sample rate

Processing @ 18kHz Sample Rate:

- Single-precision floating-point processing of 24-bit audio data; 24-bit result audio
- Multi-stage noise reduction filtering, including:
 - Dual FIR filter stages, each configurable as LMS adaptive filter (512 taps maximum), comb, lowpass, highpass, bandpass, bandstop, notch, or slot filter
 - Adaptive spectral subtraction stage, for random broadband noise reduction
 - Equalizer stage, configurable as adaptive spectral inverse filter (ASIF) or graphic equalizer
 - Automatic “Crash Detect” and reset for all adaptive filtering
- “Look-ahead” AGC, for compensation of near/far party and low-level audio signals
- Automatic voice detection module, applied to filtered output
 - Up to 2 seconds “pre-detection” and 13 seconds “post-detection” for any detected voice signal, allowing a maximum “guard band” of 15 seconds for any detected speech
 - Infinitely retriggerable, guaranteeing continuous recording if speech detected at least once each guard band period
 - Standard “C-Tone” output (852/1633 dual tone) whenever VOX active, C-Tone selected, and speech not present
- Signal flow from input to output as follows:
 - Noise reduction filters
 - VOX stage
 - AGC stage
- Interactive USB communication with Windows software allowing user configuration of the processing
- Programming of filter configuration into internal non-volatile memory
- Robust servicing of front-panel switches when USB not connected

5.4 Physical

- 1.1”W x 2.8”H x 6.0”D, extruded aluminum chassis, approximately 1 lb.
- Black painted case, black anodized front and rear panels
- Optional 2U x 19” rackmount kit, suitable for mounting up to 14 AUDIOPHILE units (vertical mounting)

