

TRANSDUCER INTERFACE POD

Model TIP //

User's Manual

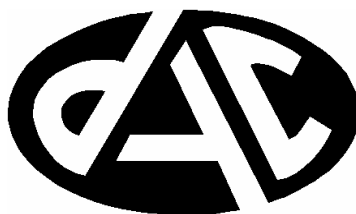

"Creating New Directions in Digital Audio Electronics"

TRANSDUCER INTERFACE POD

MODEL TIP //

USER'S MANUAL

March 26, 1999

Document Number 970580

DIGITAL AUDIO CORPORATION

A Division of Digital Recorders, Inc.

4018 Patriot Drive, Suite 300

Durham, NC 27703

Phone: 919 572 6767

Fax: 919 572 6786

www.dacaudio.com

TABLE OF CONTENTS

1.0 OVERVIEW	1
2.0 TIP // OPERATION.....	1
2.1 Front Panel Functions	1
2.2 Rear Panel Functions.....	2
2.3 Powering the Unit.....	3
3.0 BATTERY REPLACEMENT PROCEDURE	4
4.0 SPECIFICATIONS	7
5.0 KNOWLES MICROPHONE WIRING	8

TABLE OF FIGURES

Figure 1: TIP // Front Panel	1
Figure 2: TIP // Rear Panel.....	2
Figure 3: TIP II Rear Panel Thumb Screws	4
Figure 4: TIP II Rear Panel Removal	5
Figure 5: TIP II Top Cover Removal.....	5
Figure 6: TIP II Battery Removal	6
Figure 7: Knowles Microphone Wiring Diagram	8

1.0 OVERVIEW

The Transducer Interface Pod is a general-purpose preamplification system, designed specifically for use with the voice-collection microphones and accelerometers commonly used by DAC's customers. The TIP II includes 3.5mm, 1/4" and XLR microphone input jacks, as well as a BNC input jack for an accelerometer. A switchable built-in phantom supply provides 27 VDC power for studio-grade condenser microphones connected through the XLR jack, 5 VDC power for Knowles/Tibbets microphones connected through the 3.5mm jack, or 1.5 mA excitation current for Wilcoxon Research accelerometers connected through the BNC jack. With the phantom power switched off, consumer- or studio-grade dynamic microphones can also be connected through any of the mike jacks.

2.0 TIP II OPERATION

2.1 Front Panel Functions

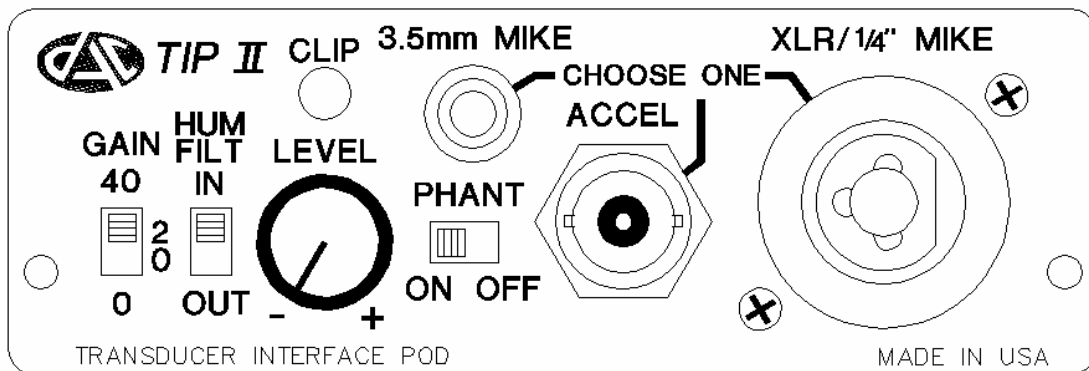

Figure 1: TIP II Front Panel

From the front panel, the user can adjust input LEVEL, switch the 6-pole 310 Hz Tschebychev HUM FILTER IN or OUT of the circuit, and apply 0 to 40dB of GAIN to the final output. Additionally, the PHANTOM SUPPLY can be switched ON or OFF as needed.

The front panel XLR/1/4" jack allows for the connection of either a standard XLR type microphone or standard 1/4" microphone. 3.5mm dynamic or Knowles/Tibbets microphone assemblies can be connected to the 3.5mm MIKE jack. Wilcoxon Research accelerometers can be directly connected to the ACCEL jack.

To vary the input level of the source signal use the LEVEL adjustment knob. The GAIN switch allows three different output gain levels to be applied to the signal in addition to the main LEVEL adjustment knob. These gain values are 0 (no gain), 20 dB (10X gain) and 40 dB (100X gain).

The PHANTOM switch on the front panel controls the PHANTOM SUPPLY. When switched into the ON position, 27 VDC is provided on the XLR jack and 5 VDC is provided on the 3.5 mm jack (NOTE: For condenser microphones the phantom must be switched ON). The phantom should only be switched ON when needed, as it places a large drain on the battery.

A CLIP (overload) LED on the front panel alerts the operator whenever there is an internal signal overload which could cause a distorted (or “clipped”) output.

2.2 Rear Panel Functions

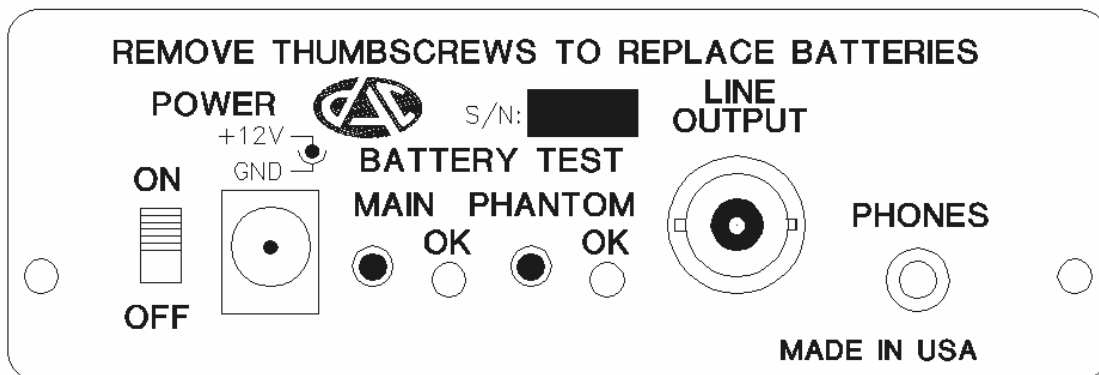

Figure 2: TIP //Rear Panel

From the rear panel, the user can power the unit ON and OFF, attach an external power supply, test the MAIN and PHANTOM batteries, and connect monitoring headphones and/or obtain a LINE OUTPUT for connection to a recorder or signal processor.

A line-level OUTPUT BNC allows the unit to be directly attached to either input of the CSP4096, as well as to any other device which accepts line-level audio input. A 1/8" stereo phone jack allows direct connection of standard 8 ohm headphones. The front panel LEVEL knob is useful in controlling the output level of the headphones, as well as the line output.

The BATTERY TEST switches indicate the status of the internal MAIN and PHANTOM batteries. If the corresponding LED fails to illuminate when either the

MAIN or PHANTOM switches are pressed, the corresponding internal 9V battery needs replacing.

2.3 Powering the Unit

The unit is powered either from internal 9VDC alkaline MAIN and PHANTOM batteries or an external 9-18 VDC power source (NOTE: Both internal batteries are disconnected whenever the external power source is plugged into the rear panel). When utilized with the CSP4096 Compact Signal Processor, a special cable allows power to be drawn from the CSP4096.



3.0 BATTERY REPLACEMENT PROCEDURE

To replace the 9V batteries:

- 1. First disconnect all cables from the unit (including the DC power cable.) Ensure that the rear power switch is in the OFF position. Loosen (if thumb screws are too tight use a flathead screwdriver) and remove the thumb screws on the rear panel.*



Be careful not to damage any of the components in the TIP II by static electricity. Before opening the unit be sure to touch a grounded metal object.

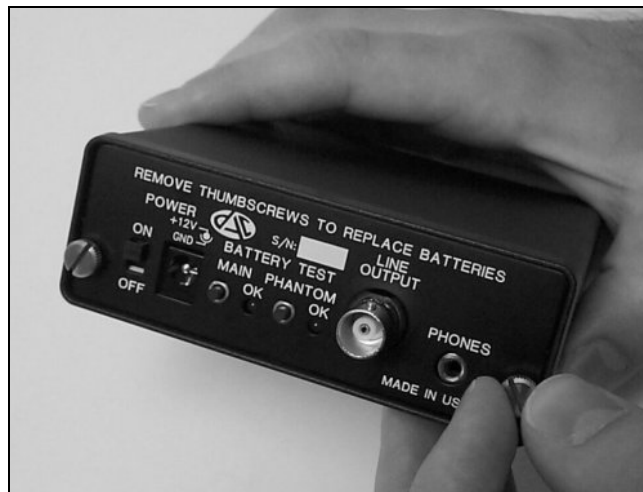

Figure 3: TIP II Rear Panel Thumb Screws

2. Remove the rear panel and bezel





Figure 4: TIP II Rear Panel Removal

3. While holding the base of the unit, gently pull the black top cover toward the rear of the unit.

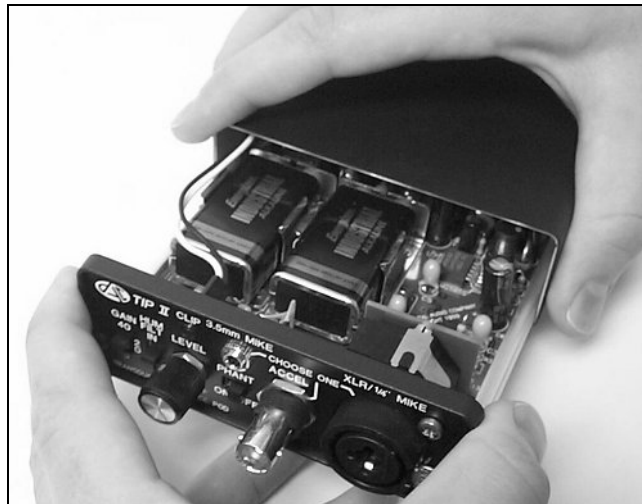

Figure 5: TIP II Top Cover Removal

4. To remove the batteries push firmly on the back (the end opposite the terminals) of each battery in the direction of the terminals while prying upward. The battery should snap out of its clips back end first.

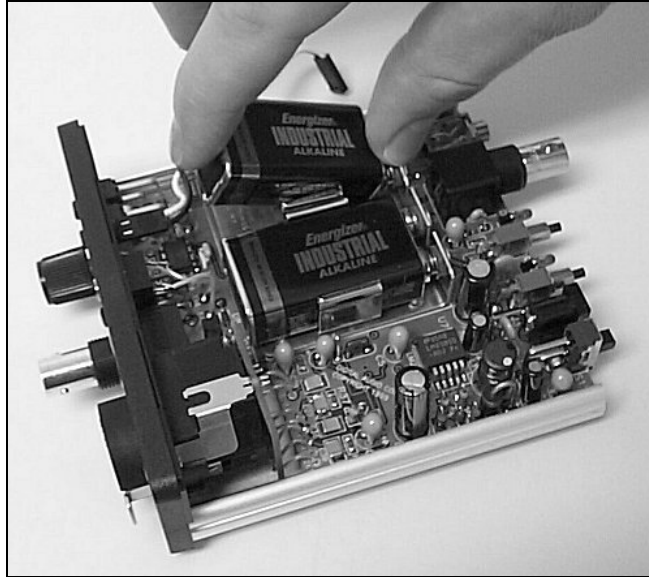

Figure 6: TIP II Battery Removal

To insert the new batteries simply reverse the previous action. First insert the terminal end of the battery by slowly prying it between the clips. Next press down on the body of the battery. It should snap into place. Ensure that it is making good contact with the connection terminals.

Replace the top cover of the TIP II by sliding it back into place. Re-tighten the thumb screws and the TIP II is again ready to use.

For applications where longer battery life is needed, longer life lithium batteries are available at many electronics stores.

4.0 SPECIFICATIONS

Input Connection:	Microphone: Combination XLR, ¼ input, or 3.5mm receptacle (compatible with Knowles/Tiblets microphone assemblies) Accelerometer: Isolated BNC, compatible with Wilcox Research accelerometers, provides constant 1.5 mA excitation current
Input Impedance:	Microphone: 10K ohms Accelerometer: 100K ohms
Phantom Power:	Switchable ON/OFF 27 VDC on XLR jack 5 VDC on 3.5 mm jack
Gain Range:	0 to +100dB from input to LINE OUTPUT and PHONES output
CMRR:	75dB or better
Equivalent input noise:	Less than 1000nVrms
Bandwidth:	100 – 10000Hz
Input Gain Stage:	0 to +60dB, continuously adjustable
Hum Filter:	Six-pole Tschebychev, highpass, 310Hz cutoff
Output Gain Stage:	0, +20, or +40dB, switchable
Line Output:	2Vrms, nominal output level Capable of driving 1K ohm load Standard isolated BNC connector
Phones Output:	1/8" stereo phone jack, drives standard 8 ohm stereo headphones
Power:	9-18VDC external DC power input Two internal 9VDC alkaline batteries
Indicators:	CLIP LED which indicates internal signal overload Battery OK LED and pushbutton switches for



testing MAIN and PHANTOM batteries.

Packaging: 1.5"H x 4"W x 4.4"L, aluminum

5.0 KNOWLES/TIBBETS MICROPHONE WIRING

The 3.5 mm microphone input on the front panel of the TIP II is configured for Knowles EK-3033 or equivalent miniature microphones. The recommended microphone wiring is given in Figure 7. No specific limitation exists on the microphone cable length. High-quality low-loss shielded cable should be used and routed to avoid noise pickup.

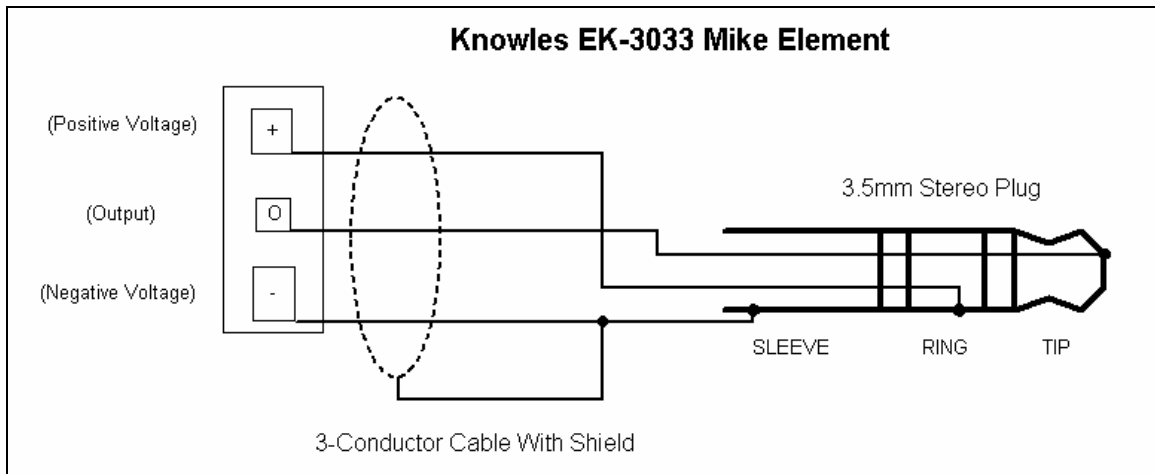

Figure 7: Knowles Microphone Wiring Diagram

